

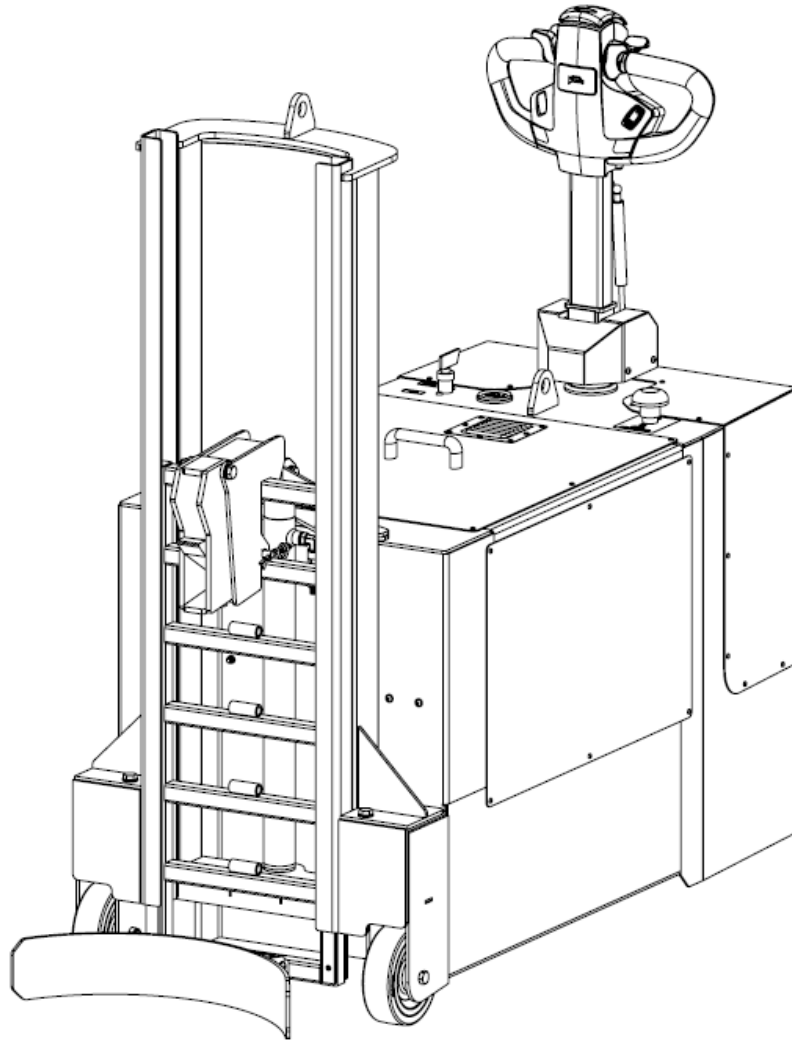

Bespoke
Handling
Equipment



Operating Instructions

DPC01

Power Drive Depalletiser with Powered Lift and
Automatic Drum Catch

Bespoke Handling Equipment Ltd.
Leedstown
Hayle
Penzance
TR27 6DS

E-mail: sales@sts-trolleys.co.uk
Tel: +44 (0)1736 851050
Fax: +44 (0)1736 851023

Section I – Correct Use and Application	2
Section II – Unit Description	5
Section III – Unit Operation	6
Charging the Battery.....	6
Battery Type.....	6
Charging Operation.....	6
Controls	7
Pre-start Inspections.....	8
Moving the Unit	8
Lifting a Drum.....	9
Unclamping the Drum.....	9
Section IV – Unit Maintenance	10
Maintenance Checklist.....	10
Consumables.....	12
Trouble Shooting	12
Section V - Technical Specification	13
General Arrangement	13
Section VI - Decommissioning the Unit	14

Section I – Correct Use and Application

General

The unit described in the present operating instructions must be used, operated and serviced in accordance with the present instructions. Any other type of use is beyond the scope of application can result in damage or injury to personnel, the unit or property. The unit described in the present operating instructions complies with BS EN ISO 17050-1:2010 and the EC Machinery Directive 2006/42/EC.

Foreseeable Misuse of the Unit

WARNING!

Personnel must take care when operating the unit. The following actions must be adhered to:

- The maximum load must not be exceeded;
- Do not travel with a raised load (>500mm);
- Do not carry or lift persons or stand on the unit;
- Do not negotiate on inclines unless otherwise stated;
- Do not stand underneath a raised load or within the confines of the unit during operation;
- Do not exceed the maximum operational speed of 4km/h;
- The load must be lifted by the attachment provided;
- Do not alter the machine specification from original supply;
- Do not disable, remove or adjust safety mechanisms or switches;
- Observe all instruction decals applied to the unit.

Approved Application Conditions

- Operation in industrial and commercial environments;
- Permissible temperature range 5°C to 40°C;
- Maximum operational relative humidity of 50%;
- Operation only on secure, level surfaces with sufficient capacity;
- Operation only on routes that are visible and approved by the proprietor;
- Operation in accordance with guidance stated within the operating instructions;
- The unit must be maintained in accordance with the maintenance schedule stated within the operating instructions.

Proprietor Responsibilities

For the purposes of the present operating instructions the "proprietor" is defined as any natural or legal person who either uses the unit themselves, or on whose behalf it is used. In special cases (e.g. leasing or renting) the proprietor is considered the person who, in accordance with existing contractual agreements between the owner and user of the unit, is charged with operational duties. The proprietor must ensure that the unit is used only for the purpose for which it is intended and that there is no danger to life or limb of the user and third parties. Furthermore, accident prevention regulations, safety regulations and operating, maintenance and repair guidelines must be followed. The proprietor must ensure that all users have read and understood these operating instructions. The proprietor must perform an onsite risk assessment before the unit is put in to service.

WARNING!

Failure to comply with the operating instructions shall invalidate the warranty. The same applies if improper work is carried out on the unit by the proprietor or third parties without the permission of the manufacturer.

Adding Attachments and/or Accessories

The mounting or installation of additional equipment which affects or enhances the performance of the unit requires written permission of the manufacturer. Local authority approval may also need to be obtained. Local authority approval does not however constitute the manufacturer's approval. An onsite risk assessment must then be carried out.

WARNING!

Any unauthorised modifications or additions to the unit shall invalidate the warranty and Bespoke Handling Equipment Ltd shall not be liable.

Safety Regulations for the Operation of the Unit

Operator authorisation

The unit may only be used by suitably trained personnel, who have demonstrated to the proprietor, or their representative that they can operate the unit safely and in accordance with the operating instructions.

Operators rights, obligations and responsibilities

The operator must be informed of their duties and responsibilities and be instructed in the operation of the unit and shall be familiar with the operating instructions. The operator shall be afforded all due rights. Safety shoes and appropriate Personal Protective Equipment (PPE) must be worn at all times.

Unauthorised use of unit

The operator is responsible for the unit during the time it is in use. The operator must prevent unauthorised persons from operating the unit.

Damage and faults

The proprietor must be immediately informed of any damage or faults to the unit or attachment. Units which are unsafe for operation must be quarantined until faults have been rectified and the unit deemed safe for operation.

Servicing and Repairs

Only original spare parts must be fitted to the unit. The operator must never disable, remove or adjust safety mechanisms or switches. The unit should only be serviced and repaired by a competent individual as selected by the company the equipment is intended for use with.

Safety devices and warning decals

Safety devices, warning decals and warning instructions in the operating instructions and on the unit must be strictly observed.

Travel routes and operational areas

Only use lanes and routes specifically designated for unit traffic. Unauthorised third parties must stay away from operational areas. The unit must only be operated in operational areas with sufficient lighting to avoid damage or injury to personnel, the unit or property. Additional equipment is necessary to operate the unit in areas of insufficient lighting.

Hazardous area of the unit

WARNING!

The hazardous area is defined as the area in which a person is at risk due to the unit itself or movement of the unit and/or load. This also includes areas which can be reached by falling loads. The operator must:

- Instruct unauthorised personnel to leave the hazardous area;
- Give a warning signal with plenty of time for personnel to leave;
- Stop all operations if unauthorised personnel are within or enter the hazardous area.

Travel conduct

The operator must adapt the travel speed to local conditions. The unit must be driven at slow speed when negotiating bends or narrow passageways, when passing through swing doors and at blind spots. Abrupt stopping (except in emergencies), rapid U turns and overtaking at dangerous or blind spots are not permitted.

Travel visibility

The operator must look in the direction of travel and must always have a clear view of the route ahead. When transporting loads that affect visibility, a second person must safely assist the operator to observe the travel route.

Type of loads to be carried

The operator must make sure that the load is in a satisfactory condition. Loads must always be positioned safely and carefully. Use suitable precautions to prevent parts of the load from tipping or falling down. Prevent liquid loads from spilling out.

Consumables and Parts

Environmental hazards

WARNING!

Parts, oils and fuels must be disposed of in accordance with the relevant environmental protection regulations.

Hydraulic hoses (if applicable)

WARNING!

Brittle hydraulic hose lines cause accidents. Hairline cracks in the hydraulic lines can cause injury and infection. The hydraulic hoses installed on the unit are supplied in accordance with BS EN 857:2015. The hydraulic hoses should only be serviced or replaced by a competent individual as selected by the company the equipment is intended for use with. The proprietor shall maintain the hydraulic hoses in accordance with BS 5244:1986.

Lift chains (if applicable)

WARNING!

Incorrectly cleaned chains can cause accidents. Lift chains are safety-critical parts. They must not contain any serious contamination. Lift chains and pivot pins must always be clean. Never clean chains with steam jet high pressure cleaners, cold or chemical cleaning agents. Immediately after cleaning, dry the lift chain with compressed air and apply a suitable chain spray.

Safety Regulations Governing the Handling of Lead-Acid Batteries (if applicable)

Maintenance Personnel

Batteries may only be charged, serviced or replaced by trained personnel. This operator manual and the manufacturer's instructions concerning batteries and charging stations must be observed when carrying out the work.

Fire Protection

Do not smoke and avoid naked flames when handling batteries. Wherever a unit is parked for charging there shall be no inflammable material or lubricants capable of creating sparks within 2m around the unit. The room must be well ventilated. Fire protection equipment must be on hand.

Battery Maintenance

The battery cell covers must be kept dry and clean. The terminals and cable shoes must be clean, secure and have a light coating of dielectric grease.

Battery Disposal

Batteries may only be disposed of in accordance with national environmental protection regulations or disposal laws. The manufacturer's disposal instructions must be followed.

WARNING!

Batteries can be hazardous

Batteries contain an acid solution which is poisonous and corrosive. Above all avoid any contact with battery acid.

- Dispose of used battery acid in accordance with regulations
- Always wear protective clothing and goggles when working with batteries
- Do not let battery acid come into contact with skin, clothing or eyes. If necessary, rinse with plenty of clean water
- Call a doctor immediately in the event of physical damage (e.g. skin or eye contact with battery acid)
- Neutralise any spilled battery acid immediately with plenty of water
- Only batteries with a sealed battery container may be used
- Follow nation guidelines and legislation

WARNING!

Using unsuitable batteries can cause accidents

The weight and dimensions of the battery have a considerable effect on the operation safety and capacity of the unit. Changing the battery features requires the manufacturer's approval, as compensating weights are required if smaller batteries are fitted. When replacing/installing the battery make sure the battery is securely located in the battery compartment of the unit.

Park the unit securely before carrying out any work on the batteries.

Charging the Battery (if applicable)

WARNING!

The gases produced during charging can cause explosions

The battery produces a mixture of nitrogen and hydrogen (electrolytic gas) during charging. Gassing is a chemical process. This gas mixture is highly explosive and must not be ignited.

- Switch the charging station and the unit off first before connecting/disconnecting the charging cable of the battery charging station to/from the battery connector
- The charger must be adapted to the battery in terms of voltage and charge capacity
- Before charging, check all cables and plug connections for visible signs of damage
- Ventilate room in which the unit is being charged
- The battery and battery cell surfaces must be exposed during charging to ensure adequate ventilation
- Do not smoke and avoid naked flames when handling batteries
- Wherever the unit is parked for charging there shall be no inflammable material or lubricants capable of creating sparks within 2m around the unit
- Fire protection equipment must be on hand
- Do not lay any metallic objects on battery
- It is essential to follow the safety regulations of the battery and charger station manufacturers

Lifting the Unit

Lifting and jacking up

WARNING!

Lifting and jacking up the unit safely

In order to raise the unit, the lifting gear must only be secured to the points specially provided for this purpose. You may only work under a raised load handler if they have been secured with a sufficiently strong chain. In order to raise and jack up the unit safely, proceed as follows:

- Jack up the unit only on a level surface and prevent it from moving accidentally
- Always use a jack with sufficient capacity. When jacking up the unit, take appropriate measures to prevent it from slipping or tipping over (e.g. wedges, wooden blocks, etc.)
- In order to raise the unit, the lifting gear must only be secured to the points specially provided for this purpose (see "Transport and Commissioning")
- When jacking up the unit, take appropriate measures to prevent it from slipping or tipping over (e.g. wedges, wooden blocks)

WARNING!

Improper lifting by crane can result in serious accidents

The use of unsuitable lifting gear can cause the unit to crash when being lifted by crane. Prevent the unit from striking other objects when it is being raised, and avoid any involuntary movements. If necessary secure the unit with guide ropes. The strap point on the mast is for loading the unit with lifting gear.

- The unit should only be handled by people who are trained in using lifting slings and tools
- Do not walk into or stand in a hazardous area
- Always use lifting gear with sufficient capacity
- Always attach the slings to the prescribed strap points and prevent them from slipping

WARNING!

Accidental movement during transport

Improper fastening of the unit and mast during transport can result in serious accidents.

- Loading must be carried out by special trained staff in accordance with recommendations contained in Guidelines BS EN 12640:2001. In each case correct measurements must be made and appropriate safety measures adopted
- The unit must be securely fastened when transported on a lorry or trailer
- The lorry/trailer must have fastening rings
- Use wedges to prevent the unit from moving
- Use only tension belts or tie-down straps or with sufficient strength

The strap point on the mast is for loading the unit with crane lifting gear.

Lifting the Unit

Requirements

- Park the unit securely

Tools and Material Required.

- Lifting gear

Procedure

- Secure Lifting slings to the strap points

The unit can now be lifted.

Securing the unit for transport

Tools and Material Required

- Tension belts/tie down straps

Procedure

- Move the unit onto the transporting truck
- Park the unit securely
- Strap the belts around the unit and tension them sufficiently, utilising the strap points on the mast

The unit can now be transported.

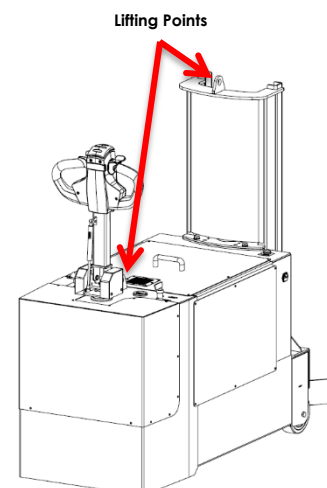

Section II – Unit Description

The DPC01 is a three-wheeled power-driven depalletiser with power lift and an automatic drum catch. It has been designed for use with a variety of steel or plastic drums.

The drum should be stood vertical; the unit can then approach and position the catch underneath the top. As the drum catch is raised via the rear mounted controls it automatically engages with the drum. With the drum secured, it can then be lifted and transported.

The unit incorporates enclosed, smooth geometry with rounded edges to ensure safe handling of the unit. The unit is fitted with a fully enclosed pump/ram unit which is operated from the rear of the unit to keep operator's limbs away from dangerous machinery movement.

The Safe Working Load (SWL) of this unit is 350kg.

This unit is designed for use on floors with a maximum slop of 2° in any direction.

Section III – Unit Operation

Charging the Battery

Battery Type

The unit is supplied with the following batteries as standard:

Battery Type	Capacity	Weight
2x Varta LDF180 513x223x223mm (LxWxH)	180Ah	2 x 45kg

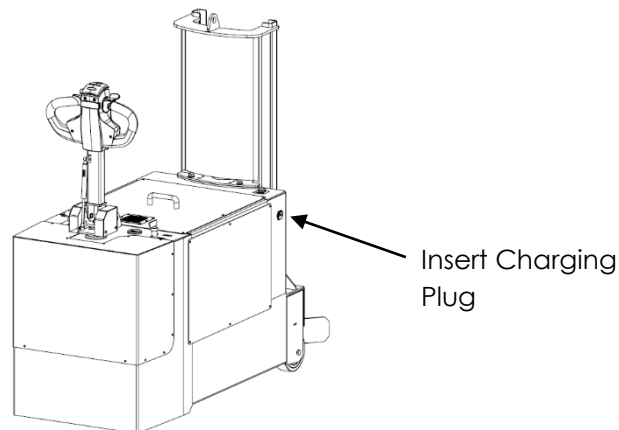

Charging Operation

Requirements

- Park the unit securely and close to a 230V charging outlet:

Procedure

- Ensure unit is turned off.
- Plug the charging cable into the socket on the side of the control box, as pictured above.
- When the charging socket cover is lifted, the power drive feature is disabled.
- The charging state is shown on the control panel.

NOTE: Battery condition meter only measures voltage in a no load situation. Under load the battery condition reading may differ. This means they can only be used as a guide to the battery status. It is possible that the unit will stop working before the battery condition meter reads 0 %. For this reason, it is a good practice to keep the unit fully charged at all times when possible. Do not allow the batteries to be left in a discharged state as permanent damage can be caused to the batteries.

IMPORTANT

Before using the DPC01 drum lifter, operators must read and understand this instruction manual. Failure to observe the instructions in this manual will invalidate the warranty.

The maximum weight of drum that the unit should be used to pick up is **350kg**.

Controls

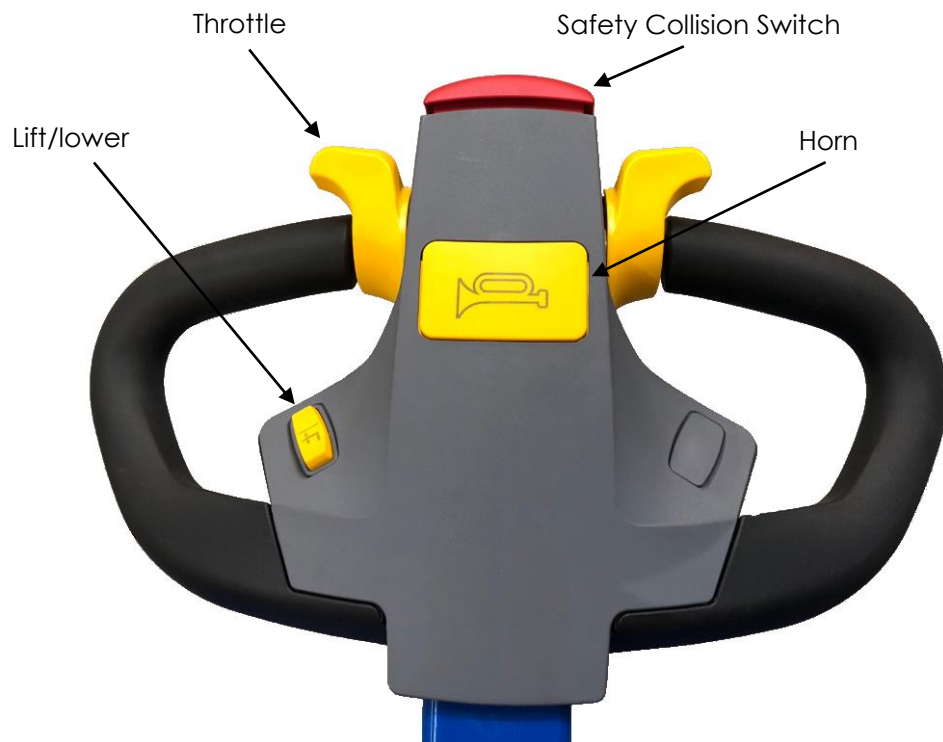
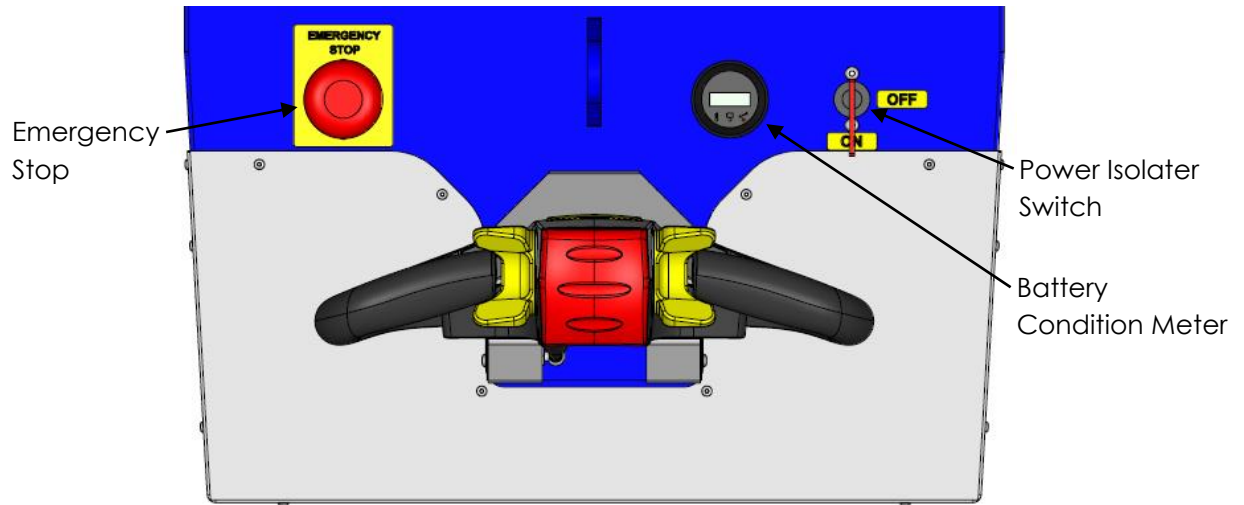

Pre-start Inspections

Procedure

- Check the whole of the outside of the unit for signs of damage and leaks. Any damaged hoses must be replaced immediately.
- Check the automatic drum catch for visible signs of damage such as cracks, bent or severely worn parts.
- Check the drive wheel and load wheels for damage.
- Check that the markings and labels are present, clean and legible.
- Check the tiller handle is restored to its normal position.
- Test the function of the emergency stop.
- Test the tiller horn.
- Check doors and/or covers are secure.
- Check the mast guarding for damage.

Moving the Unit

Requirements

- Pre-start inspection complete.
- Power isolator switch turned to 'ON'.
- Batteries charged.
- If loaded, the load must not exceed the unit's capacity.
- If loaded, load undamaged.

Procedure

- Pull back on the tiller handle.
- Use the throttle to control forwards and backwards movement. The further the throttle is rotated, the faster the unit will go.
- If the operator releases the throttle the unit will stop.
- The tiller is fitted with a safety collision switch which moves the unit forward if pressed whilst reversing. The tiller will not work when in the vertical or horizontal position. These are safety features.

THIS UNIT IS DESIGNED FOR USE ON FLAT AND LEVEL FLOOR ONLY

Lifting a Drum

Requirements

- Power isolator switch turned to 'ON'.
- Batteries charged.
- Load must not exceed the unit's capacity.
- Load undamaged.

Procedure

- Approach the drum so it aligns centrally between the mast uprights of the unit. Use the lift/lower functions to position the bottom section of the automatic drum catch just below the top lip of the drum. Use the stickers on the catch as a guide.
- Drive the unit forward until it contacts with the drum.
- Use the lift function to raise the automatic drum catch; as the catch is lifted it will securely clamp the top lip of the drum.
- Ensure that the drum is safely secured before transporting to the desired location.
- Always keep the drum as low as practicable during transport to retain the maximum stability of the unit.

Unclamping the Drum

Requirements

- Power isolator switch turned to 'ON'.
- Batteries charged.
- Load is sufficiently supported.

Procedure

- Unclamp the drum by first lowering it to the floor or a supported platform.
- Continue to lower the catch until the top lip of the catch disengages from the drum.
- Reverse the unit away from the drum.

Section IV – Unit Maintenance

Maintenance Checklist

The follow servicing checklist indicates the operations to be performed and the respective intervals to be observed. Maintenance intervals are defined as:

- W = Every 50 service hours, at least weekly
- A = Every 1000 service hours, at least annually
- = Standard maintenance interval

During the run-in period – after approx. 100 service hours – the owner must check the wheel nuts/bolts and re-tighten if necessary.

Brakes		W	A
1	Test automatic brake	●	●

Electrical System		W	A
1	Test warning and safety devices in accordance with operating instructions	●	●
2	Test emergency stop	●	●
3	Test the horn	●	●
4	Check electric wiring for damage (insulation damage, connections). Make sure wire connections are secure		●
5	Check contactors and/or relays		●
6	Carry out frame leakage test		●

Power Supply		W	A
1	Check battery and battery components		●
2	Check battery cable connections are secure, grease terminals if necessary		●
3	Check battery connector for damage, test it and make sure it is secure		●
4	Check power drive disconnects when charging		●

Travel		W	A
1	Check wheels for wear and damage	●	●
2	Clean wheels if required	●	●

Chassis and Superstructure		W	A
1	Check doors and/or covers	●	●
2	Check labels are legible and complete	●	●
3	Check guarding for damage	●	●
4	Check chassis and screw connections for damage		●
5	Check carriage and head (load handler) for wear and damage	●	●
6	Check channels and bearings for cracks and/or damage	●	●
7	Check lateral clearance of mast connections and carriage		●
8	Visually inspect the mast bearings and check the contact surface wear level	●	●

Hydraulic Operations		W	A
1	Test hydraulic system	•	•
2	Check hydraulic oil and top up if necessary	•	•
3	Check that hydraulic ports, hose and pipe lines are secure, check for leaks and damage		•
4	Check cylinders and piston rods for damage and leaks, and make sure they are secure		•
5	Test "hydraulic" controls and make sure the labels are present, legible and complete		•
6	Replace hydraulic oil		•

Agreed Performance Level		W	A
1	Carry out a test run with rated load, if necessary, with customer specified load		•

Charger		W	A
1	Check mains connector and mains cable		•
2	Check the wires and electrical connections are secure and not damaged		•

OPERATORS SHOULD REPORT ANY DEFECTS ON THE UNIT TO THE APPROPRIATE PERSON, IF IN ANY DOUBT OR YOU NEED REPLACEMENT PARTS PLEASE CONTACT THE STS TECHNICAL SUPPORT LINE.

Consumables

STS power drive units are factory-equipped with Shell Tellus 32 oil for the hydraulic system. It is recommended to use as stated or an equivalent when replacing hydraulic oil, this should be done a minimum of every two years.

Trouble Shooting

When trying to locate a fault, proceed in the order shown in the table.

NOTE:

Troubleshooting must only be performed by a suitably competent individual as decided by the company the equipment is intended for use with.

If, after carrying out the following remedial action, the unit cannot be restored to operation, contact the manufacturer's technical helpline. In order for customer services to react quickly and specifically to the fault, the following information is essential:

- Unit serial number
- Unit product name
- Description of error
- Current location / Company

Unit does not start

Possible Cause	Action
Emergency stop pressed	Reset the emergency stop button
Power isolator switch set to 'OFF'	Turn power isolator switch to 'ON'
Battery charge too low	Check battery charge and charge battery if necessary
Faulty fuse	Check fuses

Load cannot be clamped/lifted

Possible Cause	Action
The load exceeds the SWL	Reduce mass of load
Hydraulic oil level too low	Check hydraulic oil level
Faulty fuse	Check fuses
Emergency stop pressed	Reset the emergency stop button
Drum outside useable size range	-
Lip of drum insufficient for use with automatic drum catch	-

Load cannot be lowered

Possible Cause	Action
Emergency stop pressed	Reset the emergency stop button

Section V - Technical Specification

General Arrangement

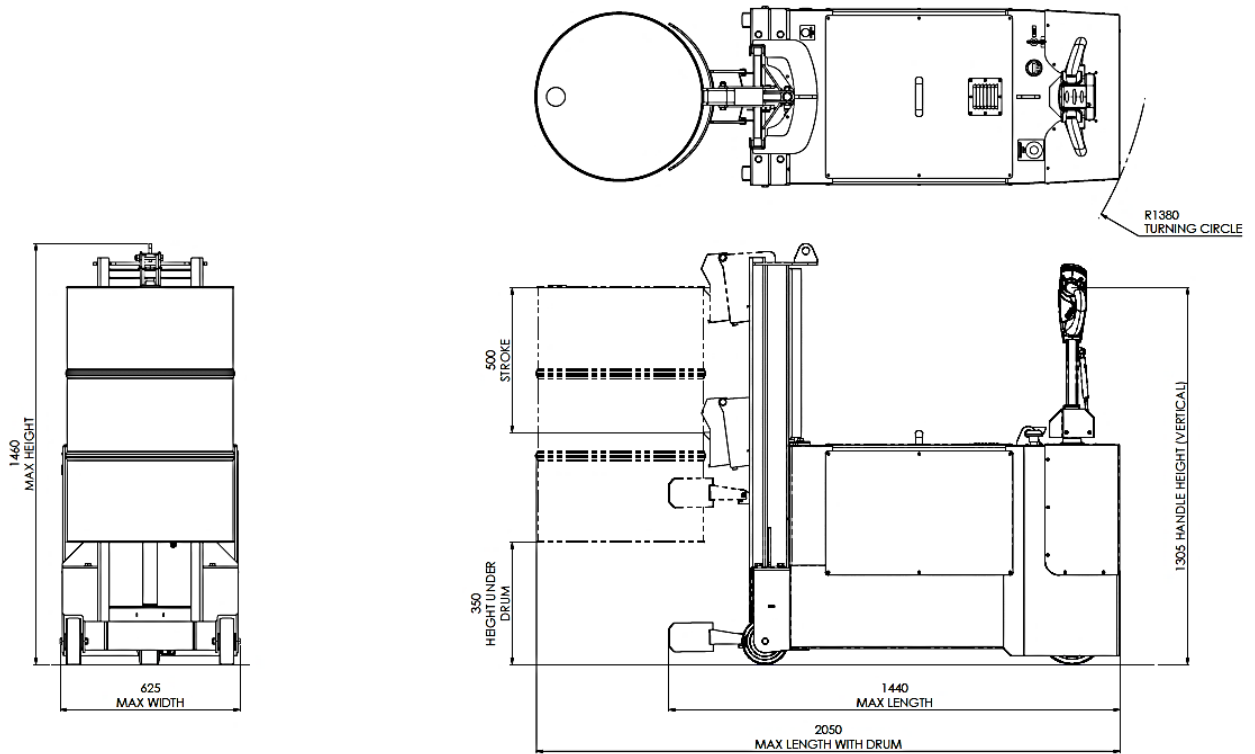

SWL 350kg
Net Mass 515kg

Max Noise Level 79dBa
System Voltage 24V

Nominal Power 1500W
Battery Mass 2 x 45kg

Section VI - Decommissioning the Unit

If the unit is to be out of service for more than a month, e.g. for commercial reasons, it must be stored in a frost-free and dry room. All necessary measures must be taken before, during and after decommissioning as described hereafter.

Prior to decommissioning

- Thoroughly clean the unit.
- Test the brakes.
- Check the hydraulic oil and replenish if necessary (if applicable).
- Apply a thin layer of oil or grease to any non-painted mechanical components.

Final De-commissioning and Disposal

Final de-commissioning or disposal of the unit must be performed in accordance with the regulations of the country of use. In particular, regulations governing the disposal of batteries, fuels and electronic and electrical systems must be observed.

The unit must only be disassembled by trained personnel.

Safety Tests to be performed at Intervals and after Unusual Incidents

Perform a safety check in accordance with national regulations.

The unit must be inspected at least annually or after any unusual event by a qualified inspector. The inspector shall assess the condition of the unit from purely a safety viewpoint, without regard to operational or economic circumstances.

For further help contact the Bespoke Handling Equipment:

Technical Support Line: 44 (0) 1736 851050

In the interest of all concerned it is essential that equipment of our manufacture is used only for the purposes for which it has been designed and it must be used in accordance with the instructions which are supplied.