

Operating Instructions

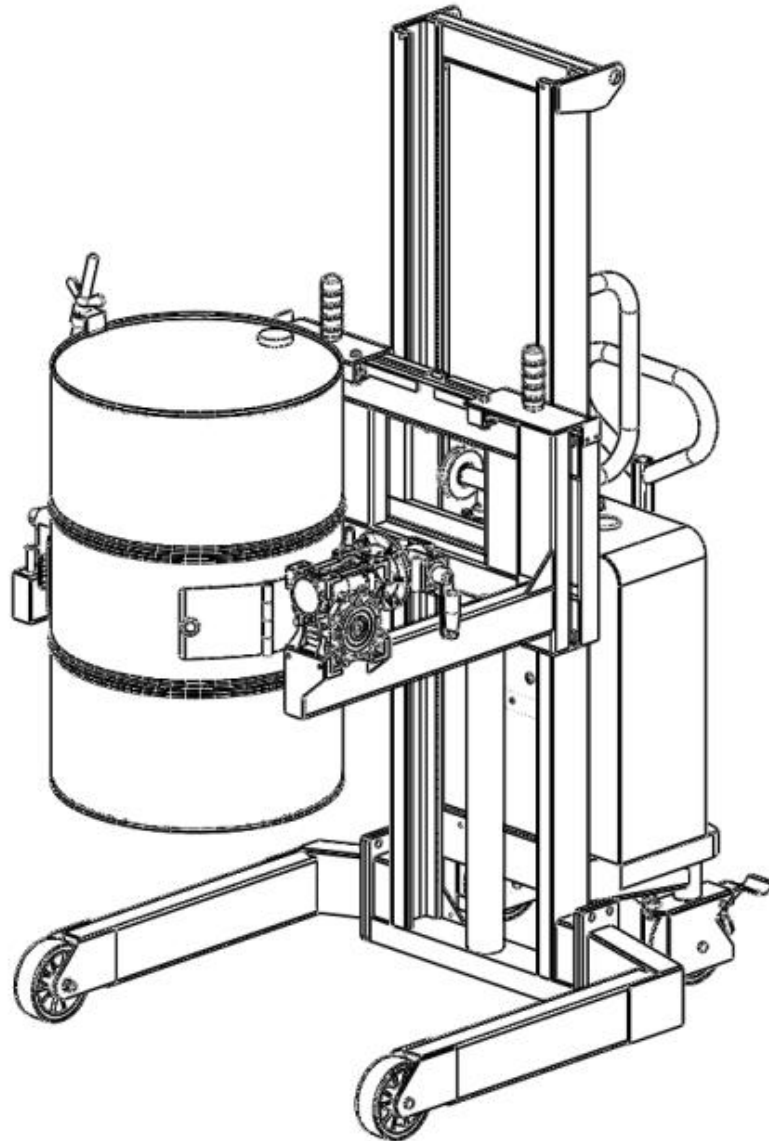

STE01-DRU01

Pedestrian Stacker with Universal Drum Rotator
Band and Manual Rotation

Bespoke Handling Equipment Ltd.
Leedstown
Hayle
Penzance
TR27 6DS

E-mail: sales@sts-trolleys.co.uk
Tel: +44 (0)1736 851050
Fax: +44 (0)1736 851023

Section I – Correct Use and Application	2
Section II – Unit Description	6
Application.....	6
Section III – Unit Operation	7
Set Up	8
Moving the Unit	8
Lifting Loads.....	8
Clamping the Drum	8
Operations of Tipping the Drum	9
Using the 25 Litre Adaptor (Optional Extra)	10
Section IV – Unit Maintenance	10
Trouble Shooting.....	10
Maintenance Checklist.....	11
Consumables	12
Section V - Technical Specification	13
Technical Specification	13
Section VI - Decommissioning the Unit	14
Final De-commissioning and Disposal.....	14
Safety Tests to be Performed at Intervals and after Unusual Incidents	14

Section I – Correct Use and Application

General

The unit described in the present operating instructions is designed for lifting, lowering and transporting load units. It must be used, operated and serviced in accordance with the present instructions. Any other type of use is beyond the scope of application and can result in damage to personnel, the unit or property.

Correct Application

NOTE:

The maximum load must not be exceeded.
The load must be lifted by the attachment provided by the manufacturer.
Correct applications of this unit are as follows:

- Lifting and lowering of loads
- Transporting lowered loads
- Do not travel with a raised load (>500mm)
- Do not carry or lift passengers
- Do not negotiate on inclines

Approved Application Conditions

- Operation in industrial and commercial environments
- Permissible temperature range 5°C to 40°C
- Operation only on secure, level surfaces with sufficient capacity
- Operation only on routes that are visible and approved by the proprietor

Proprietor Responsibilities

For the purposes of the present operating instructions the "proprietor" is defined as any natural or legal person who either uses the unit himself, or on whose behalf it is used. In special cases (e.g. leasing or renting) the proprietor is considered the person who, in accordance with existing contractual agreements between the owner and user of the unit, is charged with operational duties. The proprietor must ensure that the unit is used only for the purpose for which it is intended and that there is no danger to life and limb of the user and third parties. Furthermore, accident prevention regulations, safety regulations and operating, servicing and repair guidelines must be followed. The proprietor must ensure that all users have read and understood these operating instructions.

NOTE:

Failure to comply with the operating instructions shall invalidate the warranty. The same applies if improper work is carried out on the unit by the customer or third parties without the permission of the manufacturer.

Adding Attachments and/or Accessories

The mounting or installation of additional equipment which affects or enhances the performance of the unit requires written permission of the manufacturer. Local authority approval may also need to be obtained. Local authority approval does not however constitute the manufacturer's approval.

Safety Regulations for the Operation of the Unit

Driver authorisation

The unit may only be used by suitably trained personnel, who have demonstrated to the proprietor, or his representative that they can drive and handle the loads and have been authorised to operate the unit by the proprietor or his representative.

Driver's rights, obligations and responsibilities

The driver must be informed of his duties and responsibilities and be instructed in the operation of the unit and shall be familiar with the operating instructions. The driver shall be afforded all due rights. Safety shoes must be worn for pedestrian units.

Unauthorised use of unit

The driver is responsible for the unit during the time it is in use. The driver must prevent unauthorised persons from driving or operating the unit. Do not carry passengers or lift other people.

Damage and faults

The supervisor must be immediately informed of any damage or faults to the unit or attachment. Units which are unsafe for operation (e.g. wheel or brake problems) must not be used until they have been rectified.

Repairs

The driver must not carry out any repairs or alterations to the unit without the necessary training and authorisation to do so. The driver must never disable or adjust safety mechanisms or switches.

Hazardous area

WARNING! Risk of accidents / injury in the hazardous area of the unit.

The hazardous area is defined as the area in which a person is at risk due to unit movement, lifting operations, the handler (e.g. forks or attachments) or the load itself. This also includes areas which can be reached by falling loads or lowering operating equipment.

- Instruct unauthorised people to leave the hazardous area
- Give a warning signal with plenty of time for people to leave
- If unauthorised personnel are still within the hazardous area stop the unit immediately

Safety devices and warning labels

Safety devices, warning signs and warning instructions in the present operating instructions must be strictly observed.

Travel routes and work areas

Only use lanes and routes specifically designated for unit traffic. Unauthorised third parties must stay away from work areas. Loads must only be stored in places specifically designated for this purpose. The unit must only be operated in work areas with sufficient lighting to avoid danger to personnel and materials. Additional equipment is necessary to operate the unit in areas of insufficient lighting.

DANGER!

Do not exceed the permissible surface and spot load limits on the travel routes. At blind spots get a second person to assist.

Travel conduct

The driver must adapt the travel speed to local conditions. The unit must be driven at slow speed when negotiating bends or narrow passageways, when passing through swing doors and at blind spots. Abrupt stopping (except in emergencies), rapid U turns and overtaking at dangerous or blind spots are not permitted. Do not lean out or reach beyond the working and operating area.

Travel visibility

The driver must look in the direction of travel and must always have a clear view of the route ahead. Loads that affect visibility must have a second person walk alongside the unit as a lookout to observe the travel route while maintaining eye contact with the driver. Proceed only at walking pace and with particular care.

Negotiating slopes and inclines

Negotiating slopes or inclines is only permitted if they are specifically designed as travel routes, are clean and have a non-slip surface and providing they can be safely travelled along in accordance with the unit's technical specifications. The unit must not be turned, operated at an angle or parked on inclines or slopes. Inclines must only be negotiated at slow speed, with the driver ready to brake at any moment.

Type of loads to be carried

The operator must make sure that the load is in a satisfactory condition. Loads must always be positioned safely and carefully. Use suitable precautions to prevent parts of the load from tipping or falling down. Prevent liquid loads from sloshing out.

Negotiating lifts and docks

Lifts may only be entered if they have sufficient capacity, are suitable for driving on and authorised for unit traffic by the owner. The driver must satisfy himself of the above before entering these areas. The unit must enter lifts with the load in front and must take up a position which does not allow it to come into contact with the walls of the lift shaft. People travelling in the lift with the unit must only enter the lift after the unit has come to a halt and must exit the lift before the unit. The driver must ensure that the loading ramp/bridge cannot move or come loose during loading/unloading.

Unit Operation

WARNING!

Unsecured and incorrectly positioned loads can cause accidents

Before lifting a load unit the driver must make sure that it has been correctly positioned and does not exceed the unit's capacity.

- Instruct other people to move out of hazardous area of the unit. Stop working with the unit if people do not leave the hazardous area
- Only carry loads that have been correctly secured and positioned. Used suitable precautions to prevent parts of the load from tipping or falling down
- Damaged loads must not be transported
- Never exceed the maximum load capacity of the unit
- Never stand underneath a raised load handler
- Do not stand on the load handler
- Do not lift other people on the load handler

WARNING!

Risk of accidents and damage to components

All modifications to the unit, in particular safety mechanisms, are prohibited. The operating speeds of the unit must not be increased under any circumstances.

NOTE:

Only original spare parts have been certified by the manufacturer. To ensure safe and reliable operation of the unit, use only the manufacturer's spare parts.

Operational Safety and Environmental Protection

The checks and servicing operations contained in this chapter must be performed in accordance with the intervals as indicated in the servicing checklists.

WARNING!

Risk of accidents and damage to components

All modifications to the unit, in particular safety mechanisms, are prohibited. The operating speeds of the unit must not be increased under any circumstances.

NOTE:

Only original spare parts have been certified by the manufacturer. To ensure safe and reliable operation of the unit, use only the manufacturer's spare parts.

Maintenance Safety Regulations

Maintenance Personnel

The unit should only be serviced and repaired by a competent individual as selected by the company the equipment is intended for use with.

Lifting and jacking up

WARNING!

Lifting and jacking up the unit safely

In order to raise the unit, the lifting gear must only be secured to the points specially provided for this purpose. You may only work under a raised load handler if they have been secured with a sufficiently strong chain. In order to raise and jack up the unit safely, proceed as follows:

- Jack up the unit only on a level surface and prevent it from moving accidentally
- Always use a jack with sufficient capacity. When jacking up the unit, take appropriate measures to prevent it from slipping or tipping over (e.g. wedges, wooden blocks, etc.)
- In order to raise the unit, the lifting gear must only be secured to the points specially provided for this purpose (see "Transport and Commissioning")
- When jacking up the unit, take appropriate measures to prevent it from slipping or tipping over (e.g. wedges, wooden blocks)

Consumables and Used parts

CAUTION!

Consumables and Used parts are an environmental hazard

Used parts, oils and fuels must be disposed of in accordance with the relevant environmental protection regulations. To change the oil contact the manufacturer's customer service department, who have been specially trained for this task.

- Note the safety regulations when handling these materials

Hydraulic hoses

WARNING!

Brittle hydraulic hose lines cause accidents

The hoses must be replaced every six years. The manufacturer's customer service department is specially trained to carry out these operations.

- Comply with the safety regulations for hydraulic hose lines in accordance with BGR 237

WARNING!

Hydraulic line leaks cause accidents

Hydraulic oil can escape from leaky and faulty hydraulic lines.

- Report any defects immediately to your supervisor
- Tag out and decommission a faulty unit
- Only return the unit to service when you have identified and rectified the fault
- Spilled fluids must be removed immediately with an appropriate bonding agent. The bonding agent / consumable mixture must be disposed of in accordance with regulations

WARNING!

Hairline cracks in the hydraulic lines can cause injury and infection

Pressurised hydraulic oil can penetrate the skin through fine holes or hairline cracks in hydraulic lines, causing severe injury.

- Call for a doctor immediately if you are injured
- Do not touch pressurised hydraulic lines
- Report any defects immediately to your supervisor
- Tag out and decommission a faulty unit
- Only return the unit to service when you have identified and rectified the fault
- Spilled fluids must be removed immediately with an appropriate bonding agent. The bonding agent / consumable mixture must be disposed of in accordance with regulations

Lift Chains

WARNING!

Incorrectly cleaned chains can cause accidents

Lift chains are safety-critical parts. They must not contain any serious contamination. Lift chains and pivot pins must always be clean.

- Lift chains should only be cleaned with paraffin derivatives e.g. petroleum or diesel fuels
- Never clean chains with steam jet high pressure cleaners, cold or chemical cleaning agents
- Immediately after cleaning, dry the lift chain with compressed air and apply a chain spray

Safety Regulations Governing the Handling of Lead-Acid Batteries

Maintenance Personnel

Batteries may only be charged, serviced or replaced by trained personnel. This operator manual and the manufacturer's instructions concerning batteries and charging stations must be observed when carrying out the work.

Fire Protection

Do not smoke and avoid naked flames when handling batteries. Wherever a unit is parked for charging there shall be no inflammable material or lubricants capable of creating sparks within 2m around the unit. The room must be well ventilated. Fire protection equipment must be on hand.

Battery Maintenance

The battery cell covers must be kept dry and clean. The terminals and cable shoes must be clean, secure and have a light coating of dielectric grease.

CAUTION!

Before closing the battery tray door make sure that the battery cable cannot be damaged. There is a risk of short circuits with damaged cables.

Battery Disposal

Batteries may only be disposed of in accordance with national environmental protection regulations or disposal laws. The manufacturer's disposal instructions must be followed.

WARNING!

Batteries can be hazardous

Batteries contain an acid solution which is poisonous and corrosive. Above all avoid any contact with battery acid.

- Dispose of used battery acid in accordance with regulations
- Always wear protective clothing and goggles when working with batteries
- Do not let battery acid come into contact with skin, clothing or eyes. If necessary, rinse with plenty of clean water
- Call a doctor immediately in the event of physical damage (e.g. skin or eye contact with battery acid)
- Neutralise any spilled battery acid immediately with plenty of water
- Only batteries with a sealed battery container may be used
- Follow nation guidelines and legislation

WARNING!

Using unsuitable batteries can cause accidents

The weight and dimensions of the battery have a considerable effect on the operation safety and capacity of the unit. Changing the battery features requires the manufacturer's approval, as compensating weights are required if smaller batteries are fitted. When replacing/installing the battery make sure the battery is securely located in the battery compartment of the unit.

Park the unit securely before carrying out any work on the batteries.

Charging the Battery

WARNING!

The gases produced during charging can cause explosions

The battery produces a mixture of nitrogen and hydrogen (electrolytic gas) during charging. Gassing is a chemical process. This gas mixture is highly explosive and must not be ignited.

- Switch the charging station and the unit off first before connecting/disconnecting the charging cable of the battery charging station to/from the battery connector
- The charger must be adapted to the battery in terms of voltage and charge capacity
- Before charging, check all cables and plug connections for visible signs of damage
- Ventilate room in which the unit is being charged
- The battery and batter cell surfaces must be exposed during charging to ensure adequate ventilation
- Do not smoke and avoid naked flames when handling batteries
- Wherever the unit is parked for charging there shall be no inflammable material or lubricants capable of creating sparks within 2m around the unit
- Fire protection equipment must be on hand
- Do not lay any metallic objects on battery

- It is essential to follow the safety regulations of the battery and charger station manufacturers

Servicing and Inspection

Thorough and expert servicing is one of the most important requirements for the safe operation of the unit. Failure to perform regular servicing can lead to unit failure and poses a potential hazard to personnel and equipment.

WARNING!

The application conditions of a unit have considerable impact on the wear of the service components.

Lifting the Unit

WARNING!

Improper lifting by crane can result in serious accidents

The use of unsuitable lifting gear can cause the unit to crash when being lifted by crane. Prevent the unit from striking other objects when it is being raised, and avoid any involuntary movements. If necessary secure the unit with guide ropes. The strap point on the mast is for loading the unit with lifting gear.

- The unit should only be handled by people who are trained in using lifting slings and tools
- Do not walk into or stand in a hazardous area
- Always use lifting gear with sufficient capacity
- Always attach the slings to the prescribed strap points and prevent them from slipping

WARNING!

Accidental movement during transport

Improper fastening of the unit and mast during transport can result in serious accidents.

- Loading must be carried out by special trained staff in accordance with recommendations contained in Guidelines BS EN 12640:2001. In each case correct measurements must be made and appropriate safety measures adopted
- The unit must be securely fastened when transported on a lorry or trailer
- The lorry/trailer must have fastening rings
- Use wedges to prevent the unit from moving
- Use only tension belts or tie-down straps or with sufficient strength

The strap point on the mast is for loading the unit with crane lifting gear.

Lifting the Unit

Requirements

- Park the unit securely

Tools and Material Required

- Lifting gear

Procedure

- Secure Lifting slings to the strap point

The unit can now be lifted.

Securing the unit for transport

Tools and Material Required

- Tension belts/tie down straps

Procedure

- Move the unit onto the transporting truck
- Park the unit securely
- Strap the belts around the unit and tension them sufficiently, utilising the strap points on the mast

The unit can now be transported.

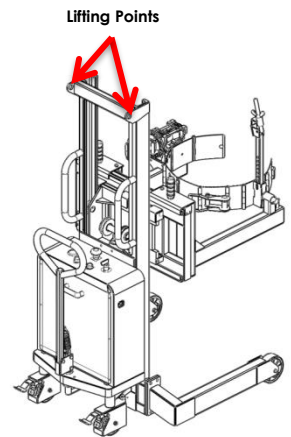

Section II – Unit Description

Application

The STE01-DRU01 is a four-wheeled pedestrian stacker with a universal drum rotator band. The STE01-DRU01 is a powered unit. It is designed for use on level surfaces to lift, rotate and transport a variety of drums.

The drum should be stood vertical; the unit can then approach the drum and straddle either side. The band is pushed flush to the drum and then fastened around the drum. Once the rim clamp is adjusted and fastened to the top lip of the drum, it can then be lifted, transported and rotated.

The STE01-DRU01 is designed to pick up and rotate 50-205L steel or plastic drums.

The unit incorporates enclosed, smooth geometry with rounded edges to ensure safe handling of the unit. The unit is fitted with a fully enclosed pump/ram unit which is operated by two-handed controls to keep operator's limbs away from dangerous machinery movement.

The Safe Working Load (SWL) of this unit is 350kg

Section III – Unit Operation

Charging Operation

Requirements

- Park the unit securely using the Rear Parking Brakes and close to a 240V charging outlet.

Procedure

- Ensure unit is turned off
- Plug the charging cable into socket on the right hand side of the control box.

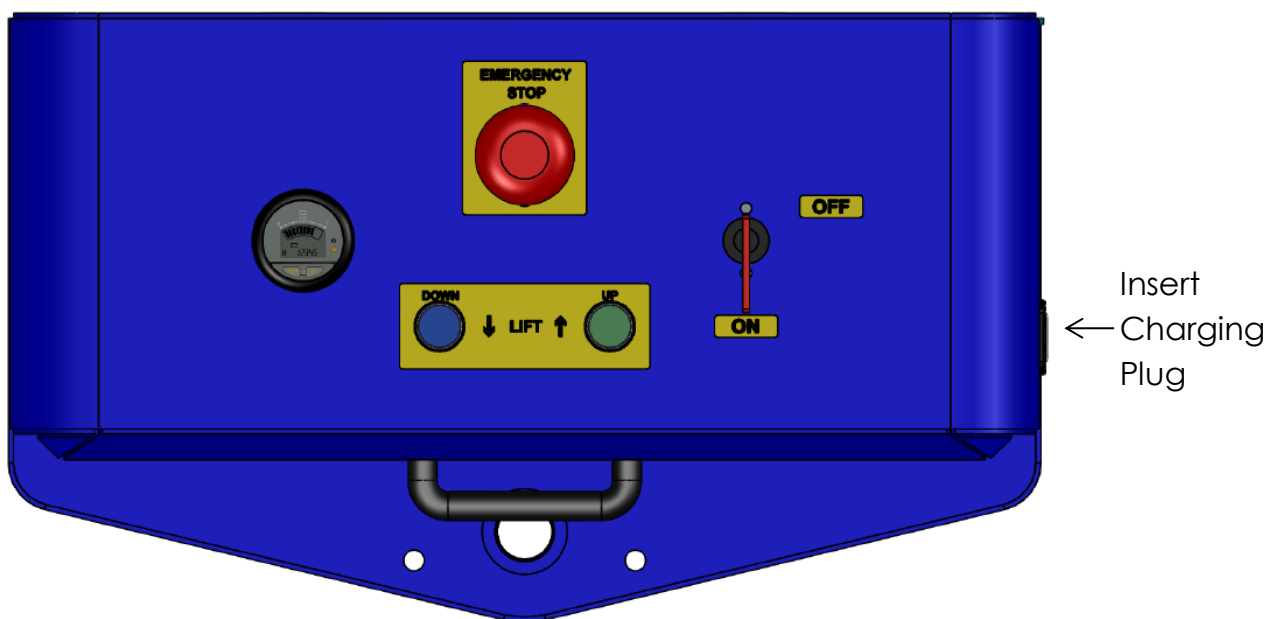

NOTE:

The Battery Condition Meter only measures voltage in a no load situation. Under load the battery condition reading may differ. This means it can only be used as a guide to the battery status. It is possible that the unit will stop working before the battery condition meter reads 0%. For this reason it is a good practice to keep the unit fully charged at all times when possible. Do not allow the batteries to be left in a discharged state as permanent damage can be caused to the batteries.

IMPORTANT

Before using the STE01-DRU01 drum lifter operators must read and understand this instruction manual. Failure to observe the instructions in this manual will invalidate the warranty.

The Maximum weight of drum that the unit should be used to pick up is **350kg**.

Set Up

1. Once the battery is charged the STE01-DRU01 is ready to use

Moving the Unit

Requirements

- Load correctly lifted
- Load at correct height for transport
- Good ground conditions

Procedure

- Disengage the Rear Parking Brakes
- The unit can then be manoeuvred to the desired location
- Steering is controlled from the rear of the stacker
- Travel at a constant speed
- Adapt your travel speed to the conditions of the route and the load you are transporting
- When finished manoeuvring the Rear Parking Brakes should be engaged

Lifting Loads

Requirements

- Unit correctly positioned
- Load does not exceed the unit's capacity

Procedure

- The lift and lower buttons on the control box move the carriage up and down when pressed.
- If the operator releases the lift or lower buttons at any stage then the carriage will stop and hold at the attained height.

Clamping the Drum

Setting the DRU01 for your drum type

1. The drum should be sitting on the floor vertically.
2. Open up the arms on the rotator to the full width.
3. Push the stacker forward so that the rotator band goes around the drum.
4. There are 2 pivot points, one on each arm. One is the gearbox pivot and the other is a free pivot. These should be positioned at the middle of the drum. (this means push or pull the stacker until the pivots are in the middle of the drum)
5. Push the two arms in so that the two pivot band sections touch the drum.

6. Adjust the height of the clamping band by raising or lowering the stacker until the clamping band is in the middle of the drum (this means top to bottom middle)
7. Adjust the back section of the clamping band to suit the diameter of the drum by removing the two locking 'R' clips from the rear of the clamping band then adjust the band to the correct diameter of the drum then refit the two 'R' clips. (The rear section of the band should be complete from the two pivot points.
8. Fold the two front sections of the drum clamp band around the front so that they touch the drum.
9. Hook the 'D' ring that is on the end of the blue strap onto the securing pin, which is on the last band section on the left hand arm.
10. Pull on the tail end of the blue ratchet strap to take out the slack with your right hand.
11. Whilst holding on to the tail end of the blue ratchet strap with your right hand, operate the ratchet with your left hand to tension the clamping band. Ensure that the blue ratchet strap enters straight and wraps evenly around the ratchet.
12. Use the ratchet to tension the clamping band. (This should be tightened until the drum starts to show signs of deflection)

13. The rim clamp must be connected to the top lip of the drum. The height can be set by removing the 'R' clip, which is close to the right hand pivot, and removing the pin. The rim clamp arm can now be set to the correct height to suit the drum size. Ensure that the top of the drum rim clamp arm is positioned under the top rim of the drum. Whilst this is being held in place the top swivelling clamp can be positioned over the rim of the drum. You can now clamp the two together by screwing down the butterfly nut. You should check that the top drum lip is securely clamped between the two sections of the drum rim clamp.

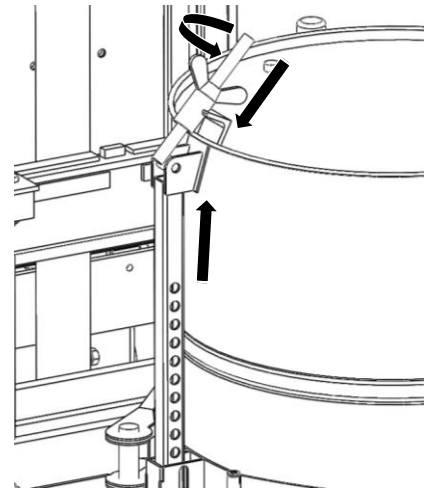

14. Replace the clamping arm adjustment pin through the body of the rotator bracket.
15. Replace the locking 'R' pin.

IMPORTANT - Check steps 1-15 have been completed correctly before you lift the drum off the floor. If you are in any doubt then contact the STS Technical support line. +44 1736 851 050

Operations of Tipping the Drum

To tip the drum the operator simply rotates the handle on the side of the DRU01 to tip the drum forwards and backwards. If the drum is tipped and the handle is released the drum will stay in its current position.

Using the 25 Litre Adaptor (Optional Extra)

The unit can also be supplied with an adaptor that is fitted to the gearbox side of the clamping band with 2 locking pins. This is used to reduce the clamping width of the clamping band. With this adaptor fitted the clamping system using the ratchet should be used. The adaptor should only be used to pick up small drums that do not fit in the normal head arrangement.

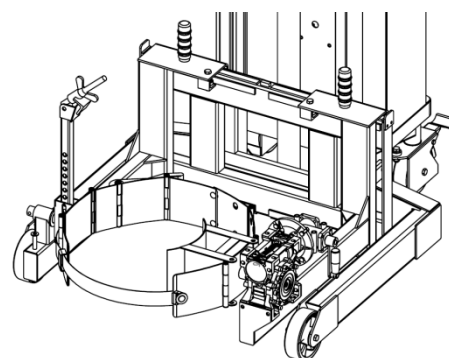

Section IV – Unit Maintenance

Trouble Shooting

When trying to locate a fault, proceed in the order shown in the table.

NOTE:

Troubleshooting must only be performed by a suitably competent individual as decided by the company the equipment is intended for use with.

If, after carrying out the following remedial action, the unit cannot be restored to operation, contact the manufacturer's technical helpline. In order for customer services to react quickly and specifically to the fault, the following information is essential:

- Unit serial number
- Unit product name
- Description of error
- Current location / Company

Unit does not start

Possible Cause	Action
Emergency Stop pressed	Unlock the Emergency Stop
Key switch set to O	Set key switch to "I"
Battery charge too low	Check battery charge and charge battery in necessary
Faulty fuse	Check fuses

Load cannot be lifted

Possible Cause	Action
The load exceeds the SWL	Reduce mass of load
Hydraulic oil level too low	Check Hydraulic oil level

Load cannot be lowered

Possible Cause	Action
Emergency Stop Operated	Reset Emergency Stop Button

Unit cannot be moved

Possible Cause	Action
Rear Parking Brakes are engaged	Release the Rear Parking Brakes

Maintenance Checklist

The following servicing checklist indicates the operations to be performed and the respective intervals to be observed. Maintenance intervals are defined as:

- W = Every 50 service hours, at least weekly
- A = Every 1000 service hours, at least annually
- = Standard maintenance interval

During the run-in period – after approx. 100 service hours – the owner must check the wheel nuts/bolts and re-tighten if necessary.

Brakes		W	A
1	Test brakes	●	●

Electrical System		W	A
1	Test warning and safety devices in accordance with operating instructions	●	●
2	Test Emergency Stops	●	●
3	Check fuse ratings		●
4	Check electric wiring for damage (insulation damage, connections). Make sure wire connections are secure		●
5	Check contactors and/or relays		●
6	Carry out frame leakage test		●

Power Supply		W	A
1	Check battery and battery components	●	●
2	Check battery cable connections are secure, grease terminals if necessary	●	●
3	Check battery connector for damage, test it and make sure it is secure	●	●

Travel		W	A
1	Check wheels for wear and damage	●	●

Chassis and Superstructure		W	A
1	Check doors and/or covers	●	●
2	Check labels are legible and complete	●	●
3	Check mast guard for damage	●	●
4	Check chassis and screw connections for damage		●

Hydraulic Operations		W	A
1	Check carriage and head (load handler) for wear and damage	●	●
2	Test hydraulic system	●	●
3	Check hydraulic oil and top up if necessary	●	●
4	Check the load chain for wear and damage, clean if necessary	●	●
5	Visually inspect the mast bearings and check contact surface wear level		●
6	Check lateral clearance of mast connections and carriage		●
7	Check the load chain and tension if necessary		●
8	Check that hydraulic ports, hose and pipe lines are secure, check for leaks and damage		●
9	Check cylinders and piston rods for damage and leaks, and make sure they are secure		●

10	Test relief valve, adjust if necessary		•
11	Test "hydraulic" controls and make sure the labels are present, legible and complete		•
12	Replace hydraulic oil		•

Agreed Performance Level		W	A
1	Carry out a test run with rated load, if necessary with customer specified load		•

Charger		W	A
1	Check mains connector and mains cable		•
2	Check the wires and electrical connections are secure and not damaged		•

Consumables

Bespoke Handling Equipment stackers are factory-equipped with Shell Tellus 32 oil for the hydraulic system. It is recommended to use as stated or an equivalent when replacing hydraulic oil, this should be done a minimum of every two years.

The blue ratchet strap of the Universal Drum Band should be replaced if any stranding of webbing is visible. These are available from Bespoke Handling Equipment. The strap should be changed twice a year even if it shows no signs of wear.

Section V - Technical Specification

Technical Specification

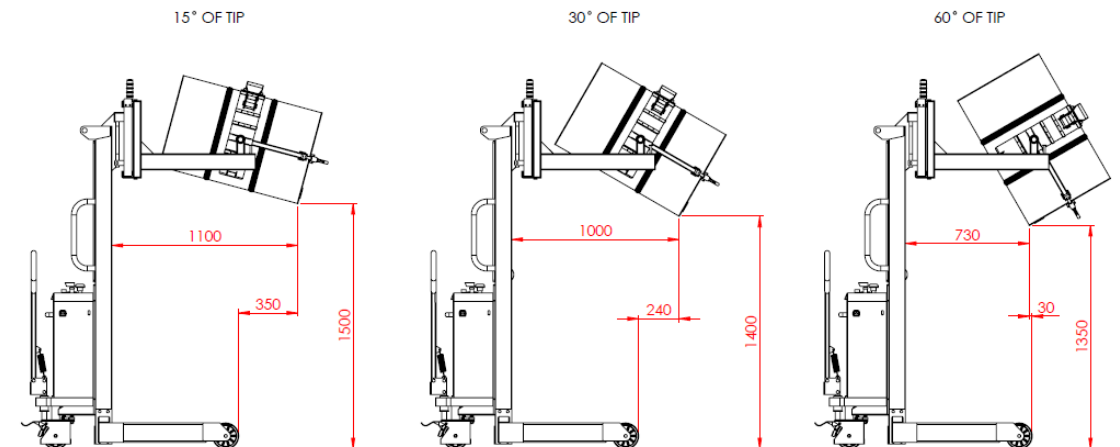
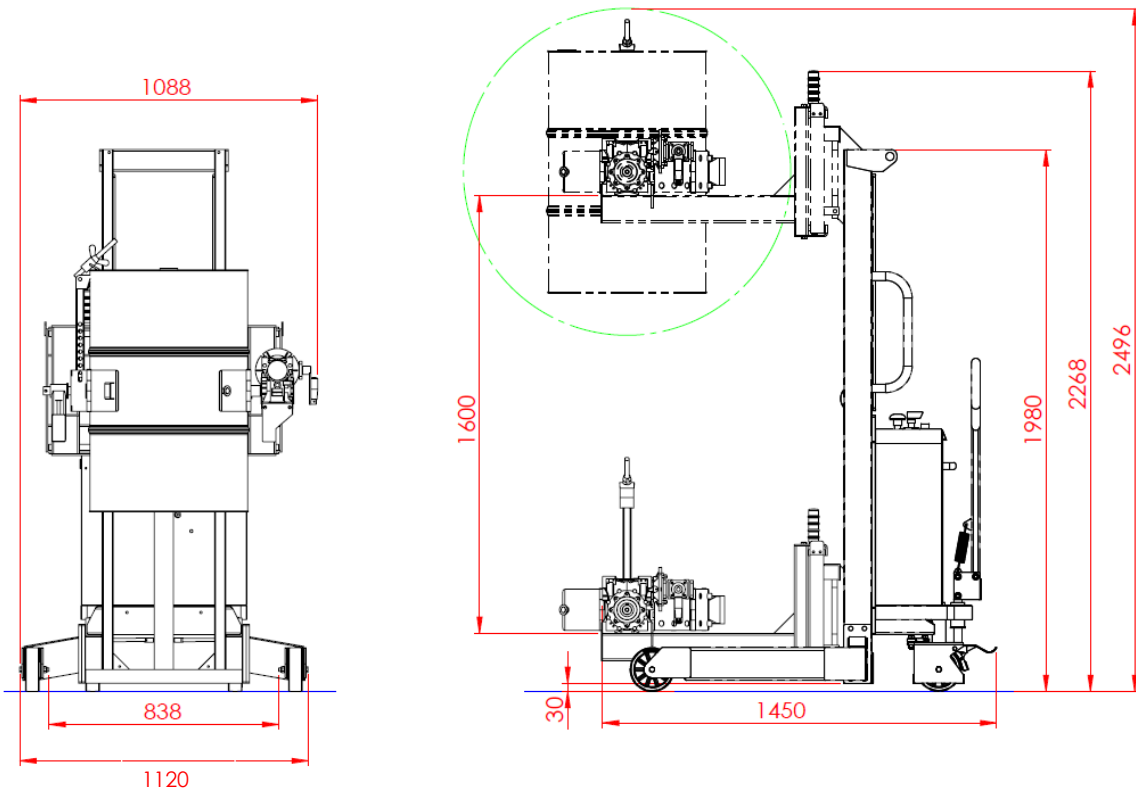

SWL. 350kg

Net Mass with Battery. 310kg

System Voltage. 12V

Max Noise Level. 79dBA

Battery Mass. 24kg

Nominal Power. 1600W

Section VI - Decommissioning the Unit

If the unit is to be out of service for more than a month, e.g. for commercial reasons, it must be stored in a frost-free and dry room. All necessary measures must be taken before, during and after decommissioning as described hereafter.

Prior to decommissioning

- Thoroughly clean the unit.
- Test the brakes
- Check the hydraulic oil and replenish if necessary.
- Apply a thin layer of oil or grease to any non-painted mechanical components.

Final De-commissioning and Disposal

Final de-commissioning or disposal of the unit must be performed in accordance with the regulations of the country of use. In particular, regulations governing the disposal of batteries, fuels and electronic and electrical systems must be observed.

The truck must only be disassembled by trained personnel.

Safety Tests to be Performed at Intervals and after Unusual Incidents

Perform a safety check in accordance with national regulations.

The unit must be inspected at least annually or after any unusual event by a qualified inspector. The inspector shall assess the condition of the unit from purely a safety viewpoint, without regard to operational or economic circumstances.

For further help contact the Bespoke Handling Equipment:

Technical Support Line: 44 (0) 1736 851050

In the interest of all concerned it is essential that equipment of our manufacture is used only for the purposes for which it has been designed and it must be used in accordance with the instructions which are supplied.